

RoHS Compliance

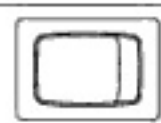

RSA-1102-12-A

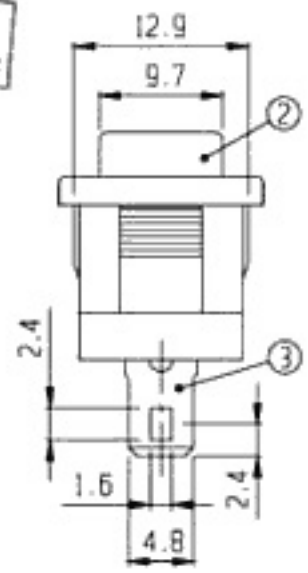
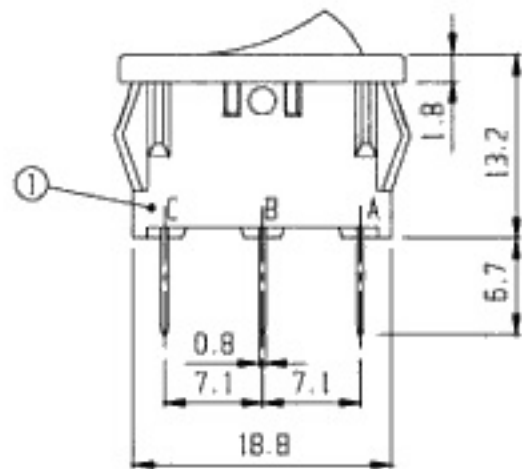
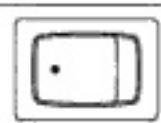

RSA-1102-12-B

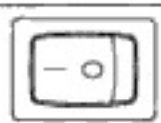

RSA-1102-12-C



RSA-1102-12-D

NO	PART	MATERIAL	QTY	REMARKS	NO	PART	MATERIAL	QTY	REMARKS
7	CONTACT POINT	Ag	4		6	BALL	STEEL	1	
5	CONTACT	BRASS	1	Ag PLATED	4	SPRING	STEEL WIRE	1	
3	TERMINAL	BRASS	3	Ag PLATED	2	KNOB	NYLON	1	
1	FRAME	NYLON	1						

ISSUED

SPECIFICATION

TITLE: ROCKER SWITCH (1P2T)



RATING: AC 125V 10A / AC 250V 6A  
 CONTACT RESISTANCE: <math>< 30m\Omega</math> (1KHz, 10mA)

MODEL NO: RSA-1102-12-( )

INSULATION RESISTANCE: >500M $\Omega$  (DC1000V)

TOLERANCE UNIT: MM DWN. *hro*

WITHSTAND VOLTAGE: 1000V AC for 1min.

UP TO 1.0:  $\pm 0.1$  SCALE: 2:1 CHK'D. *hm*

OPERATION FORCE: REFER ATTACH SPECIFICATION

1.0 TO 10.0:  $\pm 0.2$  VERSION: 01 APPD. *[Signature]*

SWITCHING LIFE: REFER ATTACH SPECIFICATION

OVER 10.0:  $\pm 0.3$  DRWG NO: